

ARMY TECHNICAL MANUAL  
NAVY PUBLICATION

AIR FORCE TECHNICAL ORDER

TM 5-6350-264-14&P-4  
NAVELEX EE 181-AA-OMI-  
050/E121 DT546 M9442  
T.O. 31S9-2FSS9-1-4

---

**TECHNICAL MANUAL**

**OPERATOR'S, ORGANIZATIONAL,  
DIRECT SUPPORT AND GENERAL SUPPORT  
MAINTENANCE MANUAL  
(INCLUDING REPAIR PARTS AND  
SPECIAL TOOLS LIST)**

**DETECTOR, VIBRATION SIGNAL  
DT-546/FSS-9(V)  
NSN 6350-00-228-2521**

**PROCESSOR, VIBRATION SIGNAL  
MX-9443/FSS-9(V)  
NSN 6350-00-228-2524**

---

**DEPARTMENTS OF THE ARMY, THE NAVY, AND THE AIR FORCE  
27 AUGUST 1982**

CHANGE }  
No. 1 }

HEADQUARTERS  
DEPARTMENTS OF THE ARMY, NAVY and AIR FORCE  
WASHINGTON, D.C. 25 September 1986

Operator's, Organizational, Direct Support, and General Support  
Maintenance Manual  
(Including Repair Parts and Special Tools List)

DETECTOR, VIBRATION SIGNAL DT-546/FSS-9(V)  
NSN 6350-00-228-2521

PROCESSOR, VIBRATION SIGNAL MX-9442/FSS-9(V)  
NSN 6350-00-228-2524

TM 5-6350-264-14&P-4/NAVELEX EE 181-AA-OMI-050/E121 DT546 M9442/T.O. 31S9-2FSS9-1-4, 27 August 1982, is changed as follows:

1. Title is changed as shown above.
2. Remove and insert pages as indicated below. New or changed text material is indicated by a vertical bar in the margin. An illustration change is indicated by a miniature pointing hand.

Remove pages

i and ii  
A-1 through A-3  
B-3 and B-4  
C-1 through C-5

Insert pages

i and ii  
A-1 and A-2  
B-3 and B-4  
C-1 through C-12

3. Retain this sheet in front of manual for reference purposes.

**By Order of the Secretaries of the Army, the Navy, and the Air Force:**

**JOHN A. WICKHAM, JR.**  
*General, United States Army*  
*Chief of Staff*

**Official:**

**R. L. DILWORTH**  
*Brigadier General, United States Army*  
*The Adjutant General*

**GLENWOOD CLARK**  
*Vice Admiral, United States Navy*  
*Commander, Naval Electronic*  
*Systems Command*

**CHARLES A. GABRIEL**  
*General, USAF*  
*Chief of Staff*

**Official:**

**EARL T. O'LOUGHLIN**  
*General, USAF, Commander, Air Force*  
*Logistics Command*

**DISTRIBUTION:**

To be distributed in accordance with DA Form 12-25A, Operator, Organizational, Direct Support and General Support Maintenance Manual for Detection System, Joint Service, Interior Intrusion (JSIIDS) (TM 5-6350-264 Series)

**WARNING**

**NOISE HAZARD**

The Audible Alarm presents a noise hazard to personnel in the area. The noise level exceeds the allowable limits for unprotected personnel. Authorized protective equipment must be worn by all personnel in the work area. If the Audible Alarm is installed, it must be disabled BEFORE any troubleshooting procedures are attempted. Disable the alarm by setting the key-operated switch on Control Unit to TEST/RESET position, opening Audible Alarm, removing faceplate, and turning off power switch. After troubleshooting the Audible Alarm must be reactivated. Activate the Alarm by setting the key-operated switch on Control Unit to TEST/RESET position, turn Alarm power switch on, replace faceplate, close and clock Audible Alarm door. Turn key-operated switch on Control Unit to SECURE or ACCESS.

**a/(b blank)**

**HEADQUARTERS  
DEPARTMENTS OF THE ARMY, NAVY and AIR FORCE  
WASHINGTON, D.C.**

**27 August 1982**

Operator's, Organizational, Direct Support, and General Support  
Maintenance Manual  
(Including Repair Parts and Special Tools List)

DETECTOR, VIBRATION SIGNAL DT-546/FSS-9(V)  
NSN 6350-00-228-2521

PROCESSOR, VIBRATION SIGNAL MX-9442/FSS-9(V)  
NSN 6350-00-228-2524

Current as of 17 April 1984

**REPORTING OF ERRORS**

You can help improve this manual. If you find any mistakes or if you know of a way to improve the procedures, please let us know. ARMY: Your letter or DA Form 2028 (Recommended Changes to Publications and Blank Forms), should be mailed to: Commander, U.S. Army Troop Support Command, ATTN: AMSTR-MCTS, 4300 Goodfellow Boulevard, St. Louis, MO 63120-1798. AIR FORCE: Completed AFTO Form 22 (Technical Order Publication Improvement Report and Reply) should be forwarded to: HQ, SA-ALC/MMEDT, Kelly AFB, TX 78241. NAVY: Completed DA Form 2028 (Recommended Changes to Publications and Blank Forms), User Activity Technical Manual Comment Sheet, Feedback Report, or other suitable reporting forms should be mailed to: Naval Electronics Systems Command Training and Publications Management Office, ATTN: ELEX. Code 8122, Washington, DC 20360.

**TABLE OF CONTENTS**

	<b>Paragraph</b>	<b>Page</b>
<b>CHAPTER 1. INTRODUCTION</b>		
Section I. General .....	1-1	1-1
II. Description and data	1-8	1-1
<b>CHAPTER 2. OPERATING INSTRUCTIONS</b>		
Section I. Operating procedures .....	2-1	2-1
II. Theory of operation .....	2-5	2-1
<b>CHAPTER 3. OPERATOR MAINTENANCE INSTRUCTIONS</b>		
Section I. Lubrication instructions (Not Applicable)		
II. Preventive maintenance checks and services (PMCS) .....	3-1	3-1
III. Troubleshooting (Not Applicable)		
IV. Maintenance procedures (Not Applicable)		

**Change 1 i**

**TABLE OF CONTENTS (Continued)**

		<b>Paragraph</b>	<b>Page</b>
CHAPTER 4.	ORGANIZATIONAL MAINTENANCE INSTRUCTIONS (Not Applicable)		
CHAPTER 5.	DIRECT SUPPORT AND GENERAL SUPPORT MAINTENANCE INSTRUCTIONS		
Section I.	Repair parts, special tools and equipment .....	5-1	5-1
II.	Troubleshooting .....	5-3	5-1
III.	General maintenance.....	5-4	5-22
IV.	Removal and replacement of major components and assemblies.....	5-5	5-22
CHAPTER 6.	REPAIR OF THE VIBRATION SENSOR (Not Applicable)		
APPENDIX A.	REFERENCES		A-1
APPENDIX B.	MAINTENANCE ALLOCATION CHART		B-1
APPENDIX C.	ORGANIZATIONAL, DIRECT SUPPORT AND GENERAL SUPPORT MAINTENANCE REPAIR PARTS AND SPECIAL TOOLS LIST .....		C-1
Section I.	Introduction .....		C-1
Section II.	Repair parts list.....		C-9
Group 01.	Vibration signal detector.....		C-9
Group 02.	Vibration signal processor .....		C-11
Section III.	Special Tools List (Not Applicable).....		C-12
Section IV.	National stock number and part number index .....		C-12

**LIST OF ILLUSTRATIONS**

<b>Figure</b>	<b>Title</b>	<b>Page</b>
1-1	Processor, Vibration Signal .....	1-0
1-2	Detector, Vibration Signal DT-546/FSS-9(V) .....	1-2
1-3	Processor Identification Plates .....	1-3
1-4	Detector Identification Plates.....	1-3
2-1	Vibration Sensor Group Simplified Block Diagram .....	2-1
5-1	Processor, Vibration Signal with Troubleshooting Test Points .....	5-20
5-2	Detector, Vibration Signal with Troubleshooting Test Points .....	5-21
C-1	Vibration Signal Detector DT-546/FSS-9(V) .....	C-8
C-2	Vibration Signal Processor MX-9442/FSS-9(V) .....	C-10

**LIST OF TABLES**

<b>Table</b>	<b>Title</b>	<b>Page</b>
3-1	Operator's Preventive Maintenance Checks and Services.....	3-1
5-1	Troubleshooting Procedures.....	5-2

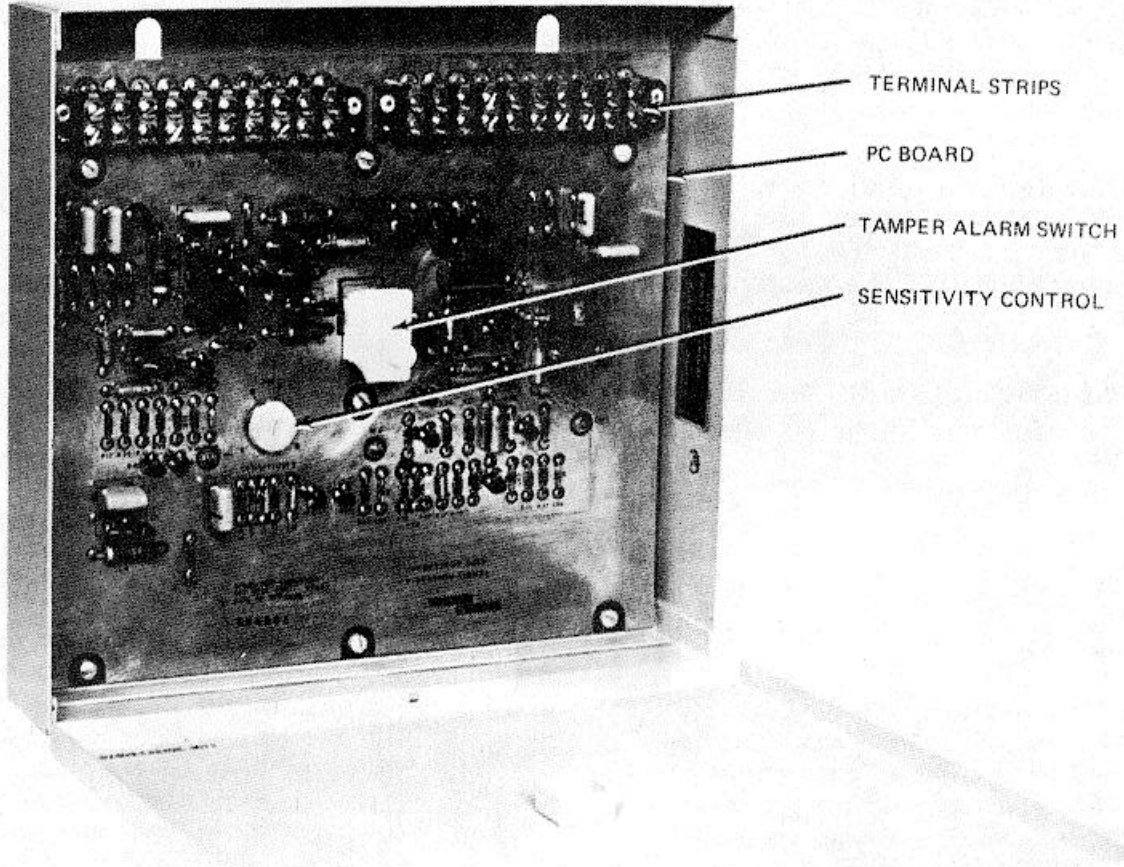

*Figure 1-1. Processor, Vibration Signal*

## CHAPTER 1 INTRODUCTION

### Section I. GENERAL

**1-1. SCOPE.** This manual is for your use in operating and maintaining the Vibration Signal Detector, Model DT-546/FSS-9(V) and Vibration Signal Processor, Model MX-9442/FSS-9(V) in their normal operating conditions. The Detector and Processor, together, make up the Vibration Sensor (VS). The VS is an integral part of the Joint-Services Interior Intrusion Detection System (J-SIIDS). For information on the major assemblies of J-SIIDS, refer to the applicable manual listed in appendix A.

#### **1-2. MAINTENANCE FORMS AND RECORDS.**

Equipment maintenance forms and procedures for their use are contained in DA Pamphlet 738-750, The Army Maintenance Management System (TAMMS).

**1-3. ADMINISTRATIVE STORAGE.** Instructions for administrative storage are contained in TM 740-90-1.

**1-4. DESTRUCTION OF ARMY MATERIEL TO PREVENT ENEMY USE.** Instructions for the

destruction of Army materiel to prevent enemy use are contained in TM 750-244-3.

**1-5. QUALITY ASSURANCE/QUALITY CONTROL.** There are no Quality Assurance/Quality Control technical manuals applicable to this equipment.

**1-6. REPORTING EQUIPMENT IMPROVEMENT RECOMMENDATIONS (EIR).** EIR's will be prepared on Standard Form 368, Quality Deficiency Report. Instructions for preparing EIR's are provided in DA Pamphlet 738-750. EIR's should be mailed directly to Commander, U.S. Army Troop Support Command, ATTN: AMSTR-QX, 4300 Goodfellow Blvd., St. Louis, Missouri 63120-1798. A reply will be furnished directly to you.

**1-7. EQUIPMENT SERVICEABILITY CRITERIA (ESC).** This equipment is not covered by an ESC.

### Section II. DESCRIPTION AND DATA

#### **1-8. Description.**

- a. The VS consists of a Processor and from one to twenty Detectors. The Sensor is one of a series of components used to detect an intrusion into a secure area. It receives power from and sends alarm signals to the J-SIIDS Control Unit.
- b. The Processor (fig. 1-1) consists of a printed circuit board (PC board) mounted inside a steel chassis. Mounted on the PC board are the sensitivity control, tamper alarm switch (TAS), terminal strips for wire connections, and all electronic components. The chassis has a removable cover and access holes where interconnecting wiring is brought in through conduit.

- c. The Detector (fig. 1-2) consists of a PC board mounted inside a steel chassis. Mounted on the PC board are the gain control, tamper alarm switch, terminal strip for wire connections, and all electronic components. The vibration sensing element protrudes through an opening in the rear of the chassis and is secured firmly to the mounting surface. The chassis has a removable cover and access holes where interconnecting wiring is brought in through conduit.

#### **1-9. Tabulated Data.**

- a. Identification Data. Two plates, identification and NSN are mounted inside each chassis. Plates for the Processor are shown in figure 1-3 and for the Detector in figure 1-4.



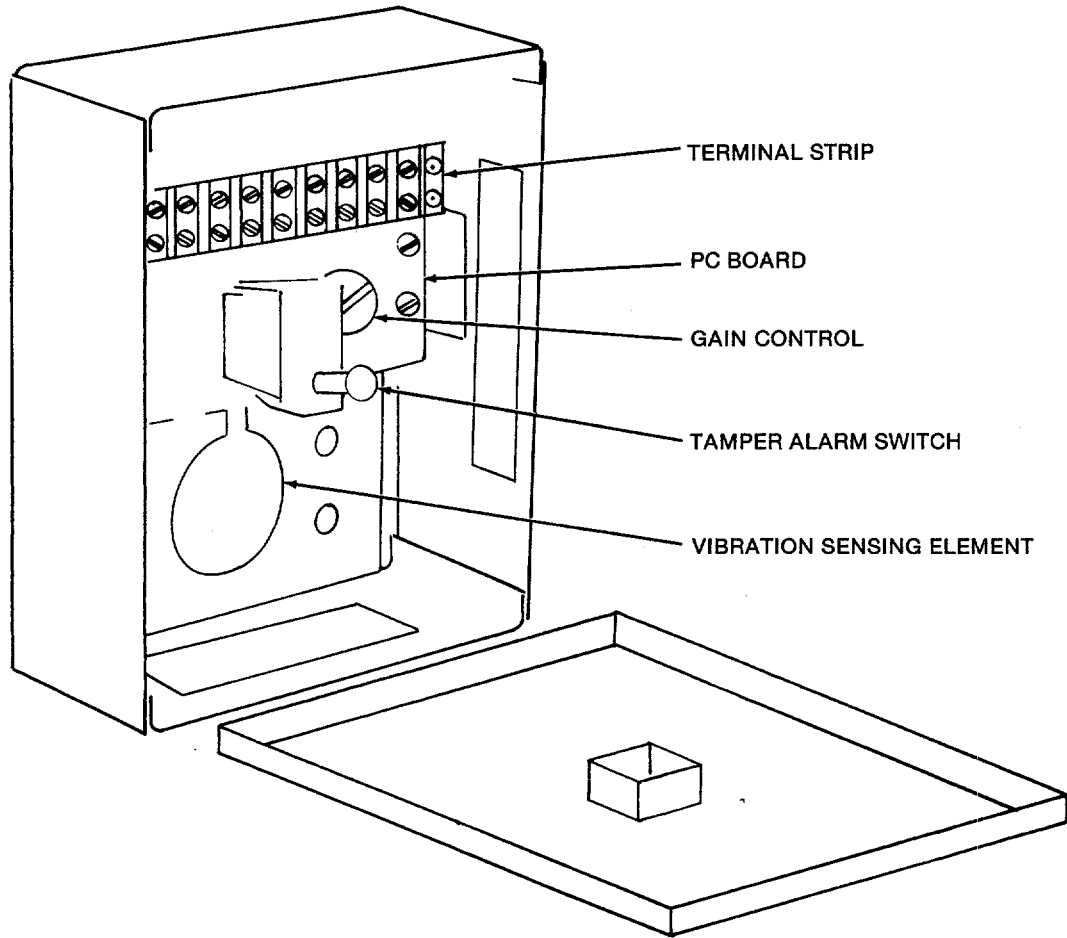

Figure 1-2. Detector, Vibration Signal DT-546/FSS-9(V)

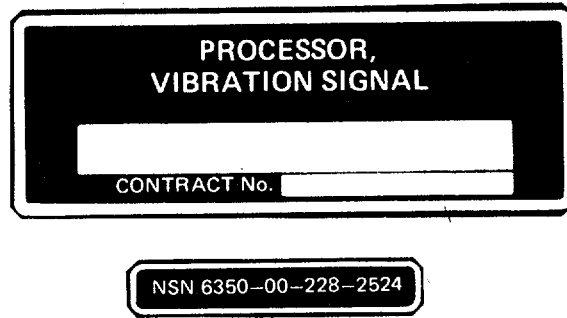

Figure 1-3. Processor Identification Plates

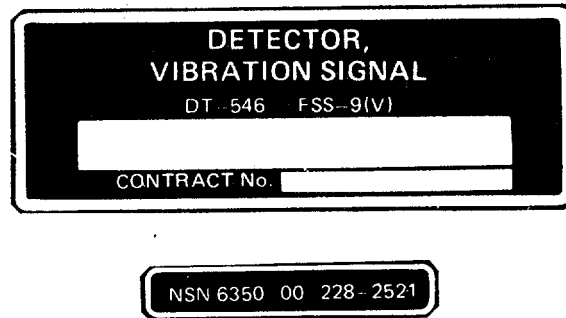

Figure 1-4. Detector Identification Plates

b. Equipment Characteristics.

		cm)	
Weight		Depth .....	2.2 inches (5.6 cm)
Detector .....	2.25 pounds (1.0 kg)	Processor	
Processor .....	6.75 pounds (3.1 kg)	Height .....	9.7 inches (24.6 cm)
Dimensions		Width .....	10.2 inches (25.9 cm)
Detector		Depth .....	2 inches (5.6 cm)
Height .....	4.8 inches (12.2 cm)		
Width .....	6.0 inches (15.2	Color (housing)	Gray per Federal Standard 595, color chip 36440, MIL-C-22751

Environmental (operational)

Temperature range ..... -20° to +150° F (-29°  
to +65°C)

Relative Humidity ..... Up to 95%

Environmental (nonoperational and storage)

Temperature range ..... -30° to +165°F (-34°  
to +74°C)

Relative humidity ..... Up to 95%

Shock..... 20 g, 11 ms duration plus bench  
handling shock

Vibration ..... Withstands  
transportation  
..... conditions

Weather resistance ..... Designed for interior  
installation

Power requirements ..... 20 ±2 vdc;  
supplied by  
J-SIIDS Control Unit

Detector ..... 0.5 ma

Processor ..... 35 ma

Alarm circuit

No alarm ..... Less than 2000-ohm  
resistance

Alarm ..... More than 100, 000-ohm  
resistance

## CHAPTER 2

### OPERATING INSTRUCTIONS

#### Section I. OPERATING PROCEDURES

**2-1. CONTROLS AND INDICATORS.** There are no operator controls or indicators applicable to this equipment.

**2-2. NORMAL OPERATING PROCEDURES.** The VS is operational after it has been installed, tested, and connected to the J-SIIDS Control Unit. Since the startup and shutdown of the VS are dependent on the presence or absence of power from the J-SIIDS Control Unit, no operating procedures are required.

**2-3. EMERGENCY OPERATION.** Operation with incomplete surveillance coverage or faulty tamper circuit should be held to a minimum. Extended periods of operation on battery (stand-by) power should be avoided.

**2-4. UNUSUAL OPERATING CONDITIONS.** Operation during periods of construction or heavy vehicular traffic will affect system sensitivity. Faulty heating or ventilating equipment operating in the immediate area will affect system performance.

#### Section II. THEORY OF OPERATION

**2-5. FUNCTIONAL DESCRIPTION.** The VS consists of a Processor and up to twenty Detectors for sensing intrusion generated vibrations in the 10- to 15-kHz (audible) range. Figure 2-1 is a simplified block diagram of the VS. The VS will detect structurally transmitted vibrations resulting from an attempted forced entry by drilling, cutting, burning, or chipping through protective barriers. The Detector will sense vibrations generated within approximately 3 feet (1 meter) of its position.

These vibrations are sent to the Processor which recognizes a vibration impulse of 100 milliseconds or longer. Four 100-msec pulses within a 15-second period or a single 4.5-second pulse will activate an alarm in the Processor. The Processor then sends an alarm signal to the J-SIIDS Control Unit. A tamper alarm signal is sent to the Control Unit whenever the cover of the Processor or a Detector is opened. The J-SIIDS Control Unit provides operating power to the VS.

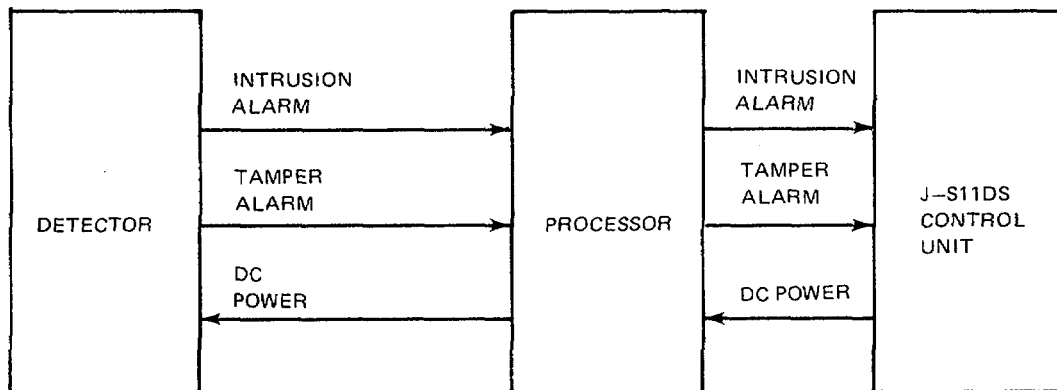

Figure 2-1. Vibration Sensor Group Simplified Block Diagram

**CHAPTER 3**

**OPERATOR MAINTENANCE INSTRUCTIONS**

**Section I. LUBRICATION INSTRUCTIONS**

This section is not applicable.

**Section II. PREVENTIVE MAINTENANCE CHECKS AND SERVICES (PMCS)**

**3-1. PMCS PROCEDURES.** The VS requires minimum organizational maintenance. The necessary PMCS to be performed are listed in table 3-1. The item numbers indicate the sequence of PMCS

requirements. Any defects occurring during operation will be noted for correction during equipment shutdown. Record all deficiencies and corrective actions on DA Form 2404.

*Table 3-1. Operator's Preventive Maintenance Checks and Services*

Sequence no.	Items to be inspected	Procedure
1.	Chassis	<div style="text-align: center; border: 1px solid black; padding: 5px; margin-bottom: 10px;"><b>CAUTION</b></div> <p>Do not use TRICHLOROETHANE or other hydrocarbon cleaning compounds.</p> <p>*Inspect interconnections and conduit for damage, secure connections, and tampering. Inspect vibration sensor (detector) for tight mounting (no free play). Ensure that cover is securely fastened to chassis and is not damaged. Inspect exterior surface for paint damage, dust, dirt, grease, rust, and corrosion. Clean exterior surface using a cloth dampened in a solution of mild detergent and water. Rinse with a cloth dampened in cold water and dry thoroughly.</p>

\*Repair not authorized at organizational level. Notify direct support maintenance personnel of any defects.

**Section III. TROUBLESHOOTING**

This section is not applicable.

**Section IV. MAINTENANCE PROCEDURES**

This section is not applicable.

**CHAPTER 4**

**ORGANIZATIONAL MAINTENANCE INSTRUCTIONS**

This chapter is not applicable to this equipment.

**4-1/(4-2 blank)**

## CHAPTER 5

### DIRECT SUPPORT AND GENERAL SUPPORT MAINTENANCE INSTRUCTIONS

#### Section I. REPAIR PARTS, SPECIAL TOOLS AND EQUIPMENT

**5-1. SPECIAL TOOLS.** No special tools are required for the Vibration Sensor.

illustrated in the repair parts and special tools list covering direct and general support maintenance for this equipment in appendix C of this manual.

**5-2. REPAIR PARTS.** Repair parts are listed and

#### Section II. TROUBLESHOOTING

##### 5-3. TROUBLESHOOTING PROCEDURES.



The Audible Alarm presents a noise hazard to personnel in the area. The noise level exceeds the allowable limits for unprotected personnel. Authorized protective equipment must be worn by all personnel in the work area.

##### NOTE

If the Audible Alarm is installed, it must be disabled BEFORE any troubleshooting procedures are attempted. Disable the Alarm by setting the key-operated switch on Control Unit to TEST/RESET position. Open Audible Alarm, remove faceplate, and turn off power switch. After troubleshooting the Audible Alarm must be reactivated. Activate the Alarm by setting the key-operated switch on Control Unit to TEST/RESET position. Turn Alarm power switch on, replace faceplate, close and lock Audible Alarm door. Turn key-operated switch on Control Unit to SECURE or ACCESS.

##### NOTE

Before you use table 5-1, be sure you have performed all applicable operating checks.

- a. This section contains troubleshooting information for locating and correcting most of the operating troubles which may develop in the Vibration Sensor. Each malfunction for an individual component, unit, or system is followed by a list of tests or inspections which will help you to determine corrective actions to take. You should perform the test/ inspections in the corrective actions column in the order listed.
- b. This manual cannot list all malfunctions that may occur, nor all tests or inspections and corrective actions. If a malfunction is not listed or is not corrected by listed corrective actions, notify your supervisor.
- c. The table lists the common malfunctions which you may find during the operation or maintenance of the Vibration Sensor or its components. You should perform the test/inspections in the corrective actions column in the order listed.
- d. Check all available information on the equipment for aid in diagnosing problems.
- e. Make a visual inspection of the equipment.



- (1) Inspect the equipment for evidence of physical damage.
- (2) Inspect terminal strips for clean and secure connections.
- (3) Inspect all wiring and cabling for worn or frayed insulation and broken wires.
- (4) Inspect all resistors for discoloration due to overheating.
- (5) Inspect the complete subsystem for the presence of dirt, corrosion, moisture, and bits of wire or solder inside the housing.

**NOTE**

Touchup paint is recommended instead of refinishing whenever practical.

- (6) Inspect all metal surfaces intended to be painted for condition of finish and legibility of panel lettering.
- f. Refer to figures 5-1 and 5-2 for all test points called out in troubleshooting table 5-1. Step-by-step troubleshooting procedures, including Trouble, Probable Cause, and Corrective Action, are listed in table 5-1.

**NOTE**

Troubleshooting procedures listed in table 5-1 may require more than one person to perform corrective action.  
 Covers should be removed as necessary to perform troubleshooting procedures.  
 Never disconnect a wire without first marking that wire to assure proper reconnection.

*Table 5-1. Troubleshooting Procedures*

Trouble	Probable cause	Corrective action
1. Constant alarm.	a. Low voltage to Processor.	a. Set multimeter to dc volts. Connect positive meter lead to TB1-7 and negative meter lead to TB1-8. Meter should indicate 20 ±2 vdc.  b. If voltage is below tolerance, disconnect wires from TB1-7 and TB1-8 and measure voltage on these wires.  (1) If voltage on wires is below tolerance, refer to TM 5-6350-264-14/10 & P on J-SIIDS Control Unit.  (2) If voltage at Control Unit is good, check wires for open circuits and shorts-to-ground per instructions in TM 5-6350-264-14/1.  c. If voltage on wires is good, replace PC board.





*Table 5-1. Troubleshooting Procedures - Continued*

Trouble	Probable cause	Corrective action
1. (cont)	b. (cont)	<p>indication should change to over 100,000 ohms. Pull the TAS plunger all the way out. The meter indication should drop to its former level. Close cover. Repeat this test on the remaining Detectors.</p> <p>d. Use a straightedge across the Processor chassis. Slowly raise the straightedge. After a movement of less than 1/4 inch (0.635 cm), the meter indication should change to over 100,000 ohms. Replace cover.</p> <p>e. If the TAS in any unit fails, replace the PC board in the failing unit.</p> <p>(1) To remove Processor PC board, tag and disconnect wires from TB1 and TB2. Remove screws that secure PC board to chassis. Lift PC board out of chassis.</p> <p>(2) To install new PC board, orient board so the terminal strips are adjacent to conduit entrance holes. Secure the PC board to chassis with screws. Connect wires to TB1 and TB2. Adjust sensitivity control per instructions in TM 5-6350-264-14/1.</p> <p>(3) To remove Detector PC board, tag and disconnect wires from TB1. Disconnect red and black pick-up assembly wires from PC board. Remove screws that secure board to chassis. Remove PC board.</p> <p>(4) To install new Detector PC board, orient board so the terminal strip is adjacent to the conduit entrance hole. Secure the board to the chassis with screws. Connect wires to TB1, and connect red and black pick-up assembly leads to the marked terminals on the board. Adjust</p>

*Table 5-1. Troubleshooting Procedures - Continued*

Trouble	Probable cause	Corrective action
1. (cont) 2. Nuisance alarms	d. (cont)  e. Loose interconnecting wiring.  a. Stray vibration in the secure area.        b. Loose ground connections.	<p style="text-align: right;">gain control per instructions in TM 5-6350-264-14/1.</p> <p>Ensure that all conduit and wire connections are tight.</p> <p>Check all mounting hardware at Detector chassis and conduit clamps to ensure that all units are mounted rigidly. Ensure that all mounting surfaces are rigid and not subject to vibration by wind, wildlife, or loose doors and windows.</p> <p>a. Set multimeter to ohms, and check between TB1-9, TB2-9, chassis, and conduit in the Processor. The meter should indicate 0 ohms.</p> <p>b. If the meter indicates any resistance, check terminal strips and PC board for damaged contacts. Ensure that all terminal connections, screws, and conduit lock nuts are tight.</p> <p>c. If there is any damage to terminal strips or PC board, replace PC board.</p> <p>(1) To remove Processor PC board, tag and disconnect wires from TB1 and TB2. Remove screws that secure PC board to the chassis. Lift PC board out of chassis.</p> <p>(2) To install new PC board, orient the board so the terminal strips are adjacent to the conduit entrance holes. Secure the PC board to the chassis with screws. Connect wires to TB1 and TB2. Adjust sensitivity control per instructions in TM 5-6350-264-14/1.</p> <p>d. Set meter to ohms, and check between TB1-9, chassis, and conduit in the Detector. The meter should indicate 0 ohms.</p>



*Table 5-1. Troubleshooting Procedures - Continued*

Trouble	Probable cause	Corrective action
2. (cont)	c. (cont)	<p>fluctuations, tap the cover. If the meter fluctuates, remove the cover. Place a straightedge across the chassis to depress the TAS. The meter should indicate less than 2,000 ohms. Slowly raise the straightedge. After a movement of less than 1/4 inch (0.635 cm), the meter indication should change to over 100,000 ohms. If the TAS checks good, replace the cover. If the TAS checks bad, replace the PC board. Repeat these tests on each Detector.</p> <p>(1) To remove Detector PC board, tag and disconnect wires from TB1. Disconnect red and black pick-up assembly wires from PC board. Remove screws that secure board to chassis. Remove PC board.</p> <p>(2) To install new Detector PC board, orient board so the terminal strip is adjacent to the conduit entrance hole. Secure the board to the chassis with screws. Connect wires to TB1, and connect red and black pick-up assembly leads to the marked terminals on the board. Adjust gain control per instructions in TM 5-6350-264-14/1.</p> <p>d. Use a straightedge across the Processor chassis to hold the TAS plunger down. Slowly raise the straightedge. After a movement of less than 1/4 inch (0.635 cm), the meter indication should change to over 100,000 ohms.</p> <p>e. If these indications are not correct, replace the Processor PC board.</p> <p>(1) To remove Processor PC board, tag and disconnect wires from TB1 and TB2. Remove screws</p>

*Table 5-1. Troubleshooting Procedures - Continued*

Trouble	Probable cause	Corrective action
2. (cont)	<p>c. (cont)</p> <p>d. Bad Detector pick-up assembly.</p> <p>e. Gain or sensitivity controls set too high.</p>	<p>that secure PC board to chassis. Lift PC board out of chassis.</p> <p>(2) To install new PC board, orient board so the terminal strips are adjacent to conduit entrance holes. Secure the PC board to chassis with screws. Connect wires to TB1 and TB2. Adjust sensitivity control per instructions in TM 5-6350-264-14/1.</p> <p>a. If PC board is good, check pick-up assembly in Detector. Disconnect red and black leads from PC board. Set multimeter to ohms (highest scale), and connect meter leads to red and black leads. Meter should indicate over 10,000,000 ohms.</p> <p>b. If this indication is not present, replace pick-up assembly.</p> <p>(1) To remove pick-up assembly, disconnect red and black leads from PC board. Remove screws that secure assembly to mounting surface, and remove assembly.</p> <p>(2) To install new pick-up assembly, orient assembly so that red and black leads are toward PC board. Tilt assembly so that edge nearest PC board can be slipped under PC board. Insert assembly into chassis, flat against mounting surface, and secure it with screws. Connect red and black leads to PC board.</p> <p style="text-align: center;"><b>NOTE</b></p> <p>BEFORE touching any gain or sensitivity controls, note their settings so that they may be returned to original positions after testing.</p>



*Table 5-1. Troubleshooting Procedures - Continued*

Trouble	Probable cause	Corrective action
2. (cont)	<p>e. (cont)</p> <p style="padding-left: 40px;">f. Bad Processor PC board.</p> <p style="padding-left: 40px;">g. Bad Detector PC board.</p>	<p>Check settings of Detector gain and Processor sensitivity controls to ensure that they are not set to maximum (10).</p> <p>a. Disconnect wire from TB1-7 in the Processor. Set multimeter to ohms, and connect leads to the plus (+) side of C13 and TB2-2.</p> <p>b. Turn the sensitivity control as far as it will go in each direction. As the sensitivity control is turned, the meter should sweep between 0 and approximately 2,500 ohms.</p> <p>c. If the meter does not sweep between 0 and approximately 2,500 ohms or if the needle moves in a jerky or erratic manner, replace the PC board.</p> <p>(1) To remove Processor PC board, tag and disconnect wires from TB1 and TB2. Remove screws that secure PC board to chassis. Lift PC board out of chassis.</p> <p>(2) To install new PC board, orient board so the terminal strips are adjacent to conduit entrance holes. Secure the PC board to chassis with screws. Connect wires to TB1 and TB2. Adjust sensitivity control per instructions in TM 5-6350-264-14/1.</p> <p>a. Disconnect wire from TB1-7 in the Processor. Set multimeter to ohms, and connect leads to the negative (-) side of C3 and TB1-2 in the Detector.</p> <p>b. Turn the gain control as far as it will go in each direction. As the gain control is turned, the meter should sweep between 0 and approximately 2,500 ohms.</p>

*Table 5-1. Troubleshooting Procedures - Continued*

Trouble	Probable cause	Corrective action
2. (cont)	g. (cont)	<p>c. If the meter does not sweep between 0 and approximately 2,500 ohms or if the needle moves in a jerky or erratic manner, replace the PC board.</p> <p>(1) To remove Detector PC board, tag and disconnect wires from TB1. Disconnect red and black pick-up assembly wires from PC board. Remove screws that secure board to chassis. Remove PC board.</p> <p>(2) To install new Detector PC board, orient board so the terminal strip is adjacent to the conduit entrance hole. Secure the board to the chassis with screws. Connect wires to TB1, and connect red and black pick-up assembly leads to the marked terminals on the board. Adjust gain control per instructions in TM 5-6350-264-14/1.</p> <p>Ensure that all conduit and wire connections are tight.</p>
3. Poor sensitivity.	<p>h. Loose interconnecting wiring.</p> <p>a. Bad Processor PC board.</p>	<p>a. Set multimeter to dc volts. Connect positive meter lead to TB2-1 and negative meter lead to TB2-2. Check for 5.3 ±0.5 Vdc.</p> <p>b. If voltage is below tolerance, disconnect wires from TB2-1 and TB2-2 and check the voltage on these terminals.</p> <p>c. If voltage is still below tolerance, replace Processor PC board.</p> <p>(1) To remove Processor PC board, tag and disconnect wires from TB1 and TB2. Remove screws that secure PC board to the chassis. Lift PC board out of chassis.</p>

Table 5-1. Troubleshooting Procedures - Continued

Trouble	Probable cause	Corrective action
3. (cont)	<p style="text-align: center;">a. (cont)</p> <p style="text-align: center;">b. Bad interconnecting wiring.</p> <p style="text-align: center;">c. Bad Detector PC board.</p>	<p>(2) To install new PC board, turn the PC board so TB1 is adjacent to the conduit entrance holes and place the board in the chassis. Secure the board to the chassis with screws, and connect wires to TB1 and TB2. Adjust sensitivity control per instructions in TM 5-6350-264-14/1.</p> <p>a. If voltage is normal with wires disconnected from TB2-1 and TB2-2, check wiring for shorts-to-ground.</p> <p>b. To check for a grounded circuit, disconnect wires from TB2-1 and TB2-2 in the Processor and from TB1-1 and TB1-2 in the Detector. Set multimeter to ohms, and check between the wires and conduit. An indication of infinity means a good wire. Any indication of less than infinity means a short-to-ground.</p> <p>c. Replace any bad wiring.</p> <p>a. If voltage at TB2-1 and TB2-2 is normal and wiring checks good, disconnect wire from TB1-7 in the Processor; reconnect wires to TB1-1 and TB1-2 in the Detector; and set multimeter to ohms. Use meter to check between wires removed from TB2-1 and TB2-2. The meter should indicate some value of resistance for one polarity and some value of resistance several times higher or lower for the other polarity.</p> <p>b. Connect the wires to TB1-7, TB2-1 and TB2-2 in the Processor. Set the meter to dc volts. In the Detector, connect positive meter lead to TB1-1 and negative meter lead to TB1-2. Check for 5.3 ±0.5 Vdc.</p>



*Table 5-1. Troubleshooting Procedures - Continued*

Trouble	Probable cause	Corrective action
3. (cont)	e. (cont)	<ul style="list-style-type: none"> <li>c. If the meter does not sweep between 0 and approximately 2,500 ohms or if the needle moves in a jerky or erratic manner, replace the PC board.               <ul style="list-style-type: none"> <li>(1) To remove Processor PC board, tag and disconnect wires from TB1 and TB2. Remove screws that secure PC board to chassis. Lift PC board out of chassis.</li> <li>(2) To install new PC board, orient board so the terminal strips are adjacent to conduit entrance holes. Secure the PC board to chassis with screws. Connect wires to TB1 and TB2. Adjust sensitivity control per instructions in TM 5-6350-264-14/1.</li> </ul> </li> </ul>
	f. Bad Detector pick-up assembly	<ul style="list-style-type: none"> <li>a. If PC board is good, check pick-up assembly in Detector. Disconnect red and black leads from PC board. Set multimeter to ohms (highest scale), and connect meter leads to red and black leads. Meter should indicate over 10,000,000 ohms.</li> <li>b. If this indication is not present, replace pick-up assembly.               <ul style="list-style-type: none"> <li>(1) To remove pick-up assembly, disconnect red and black leads from PC board. Remove screws that secure assembly to mounting surface, and remove assembly.</li> <li>(2) To install new pick-up assembly, orient assembly so that red and black leads are toward PC board. Tilt assembly so that edge nearest PC board can be slipped under PC board. Insert assembly into chassis, flat against mounting surface, and secure it with screws. Connect red and black leads to PC board.</li> </ul> </li> </ul>

*Table 5-1. Troubleshooting Procedures - Continued*

Trouble	Probable cause	Corrective action
3. (cont)	g. Bad Detector PC board.	<p>a. Set multimeter to dc volts. Connect positive meter lead to TP MV and negative meter lead to TP GND.</p> <p>b. Meter should indicate 0 Vdc.</p> <p>c. Tap conduit or mounting surface next to each Detector.</p> <p>d. After each series of taps, meter should indicate about <math>11 \pm 3</math> Vdc and then return to 0.</p> <p>e. If this indication is not present at any Detector, replace that Detector PC board.</p> <p>(1) To remove Detector PC board, tag and disconnect wires from TB1. Disconnect red and black pick-up assembly wires from PC board. Remove screws that secure board to chassis. Remove PC board.</p> <p>(2) To install new Detector PC board, orient board so the terminal strip is adjacent to the conduit entrance hole. Secure the board to the chassis with screws. Connect wires to TB1, and connect red and black pick-up assembly leads to the marked terminals on the board. Adjust gain control per instructions in TM 5-6350-264-14/1.</p>
	h. Loose ground connections.	<p>a. Set multimeter to ohms, and check between TB1-9, TB2-9, chassis, and conduit in the Processor. The meter should indicate 0 ohms.</p> <p>b. If the meter indicates any resistance, check terminal strips and PC board for damage contacts. Ensure that all terminal connections, screws, and conduit lock nuts are tight.</p>

*Table 5-1. Troubleshooting Procedures - Continued*

Trouble	Probable cause	Corrective action
3. (cont)	h. (cont)	<p>c. If there is any damage to terminal strips or PC board, replace PC board.</p> <p>(1) To remove Processor PC board, tag and disconnect wires from TB1 and TB2. Remove screws that secure PC board to the chassis. "Lift PC board out of chassis.</p> <p>(2) To install new PC board, orient the board so the terminal strips are adjacent to the conduit entrance holes. Secure the PC board to the chassis. Connect wires to TB1 and TB2. Adjust sensitivity control per instructions in TM 5-6350-264-14/1.</p> <p>d. Set meter to ohms, and check between TB1-9, chassis, and conduit in the Detector. The meter should indicate 0 ohms.</p> <p>e. If the meter indicates any resistance, check terminal strip and PC board for damaged contacts. Ensure that all terminal connections, screws, and conduit lock nuts are tight.</p> <p>f. If there is any damage to terminal strip or PC board, replace PC board.</p> <p>(1) To remove Detector PC board, tag and disconnect wires from TB1. Disconnect red and black pick-up assembly wires from PC board. Remove screws that secure board to chassis. Remove PC board.</p> <p>(2) To install new Detector PC board, orient board so the terminal strip is adjacent to the conduit entrance hole. Secure the board to the chassis with screws. Connect wires to TB1, and connect red and black pick-up assembly</p>

*Table 5-1. Troubleshooting Procedures - Continued*

Trouble	Probable cause	Corrective action
3. (cont)	h. (cont)	leads to the marked terminals on the board. Adjust gain control per instructions per TM 5-6350-264-14/1.
	i. Loose interconnecting wiring.	Ensure that all conduit and wire connections are tight.
4. No alarms.	a. Bad Processor Detector PC board.	<p>a. Disconnect wire from TB1-1. Set meter to ohms and connect leads to TB1-1 and TB1-2. Meter should indicate 2,000 ohms or less. Disconnect wire from TB1-7. Meter indication should change to over 100, 000 ohms.</p> <p>b. Connect wire to TB1-7, set multi-meter to dc volts. Connect positive meter lead to TP MV and negative meter lead to TP GND. Meter should indicate 0 Vdc. Tap conduit or mounting surface next to Detector. After each series of taps, meter should indicate about 11 ±3 Vdc and then return to 0.</p> <p>c. If the resistance indications are incorrect or if the voltage indications at TP MV/TP GND are incorrect for all Detectors, replace the Processor PC board. If the voltage indications at TP MV/TP GND are correct for some Detectors and incorrect for others, replace the PC board(s) in the Detector(s) that give incorrect indications.</p> <p>(1) To remove Processor PC board, tag and disconnect wires from TB1 and TB2. Remove screws that secure PC board to chassis. Lift PC board out of chassis.</p> <p>(2) To install new PC board, orient board so the terminal strips are adjacent to conduit entrance holes. Secure the PC board to chassis with screws. Connect</p>



Table 5-1. Troubleshooting Procedures - Continued

Trouble	Probable cause	Corrective action
4. (cont)	<p data-bbox="402 344 509 375">a. (cont)</p> <p data-bbox="402 1016 662 1077">b. Bad Detector pick-up assembly.</p>	<p data-bbox="971 344 1318 434">wires to Tb1 and TB2. Adjust sensitivity control per instructions in TM 5-6350-264-14/1.</p> <p data-bbox="940 468 1396 678">(3) To remove Detector PC board, tag and disconnect wires from TB1. Disconnect red and black pick-up assembly wires from PC board. Remove screws that secure board to chassis. Remove PC board.</p> <p data-bbox="940 711 1401 982">(4) To install new Detector PC board, orient board so the terminal strip is adjacent to the conduit entrance hole. Secure the board to the chassis with screws. Connect wires to TB1, and connect red and black pick-up assembly leads to the marked terminals on the board.</p> <p data-bbox="902 1016 1396 1226">a. If PC board is good, check pick-up assembly in Detector. Disconnect red and black leads from PC board. Set multimeter to ohms (highest scale), and connect meter leads to red and black leads. Meter should indicate over 10,000,000 ohms.</p> <p data-bbox="922 1260 1364 1320">b. If this indication is not present, replace pick-up assembly.</p> <p data-bbox="940 1354 1401 1535">(1) To remove pick-up assembly, disconnect red and black leads from PC board. Remove screws that secure assembly to mounting surface, and remove assembly.</p> <p data-bbox="940 1568 1411 1866">(2) To install new pick-up assembly, orient assembly so that red and black leads are toward PC board. Tilt assembly so that edge nearest PC board can be slipped under PC board. Insert assembly into chassis, flat against mounting surface, and secure it with screws. Connect red and black leads to PC board.</p>

*Table 5-1. Troubleshooting Procedures - Continued*

Trouble	Probable cause	Corrective action
4. (cont)	<ul style="list-style-type: none"> <li>c. Loose interconnecting wiring.</li> <li>d. Gain or sensitivity controls set too low.</li> </ul>	<p>Ensure that all conduit and wire connections are tight.</p> <p style="text-align: center;"><b>NOTE</b></p> <p>BEFORE touching any gain or sensitivity controls, note their settings so that they may be returned to their original positions after testing.</p> <p>Check settings of Detector gain and Processor sensitivity controls to ensure that they are not set to minimum (1).</p>

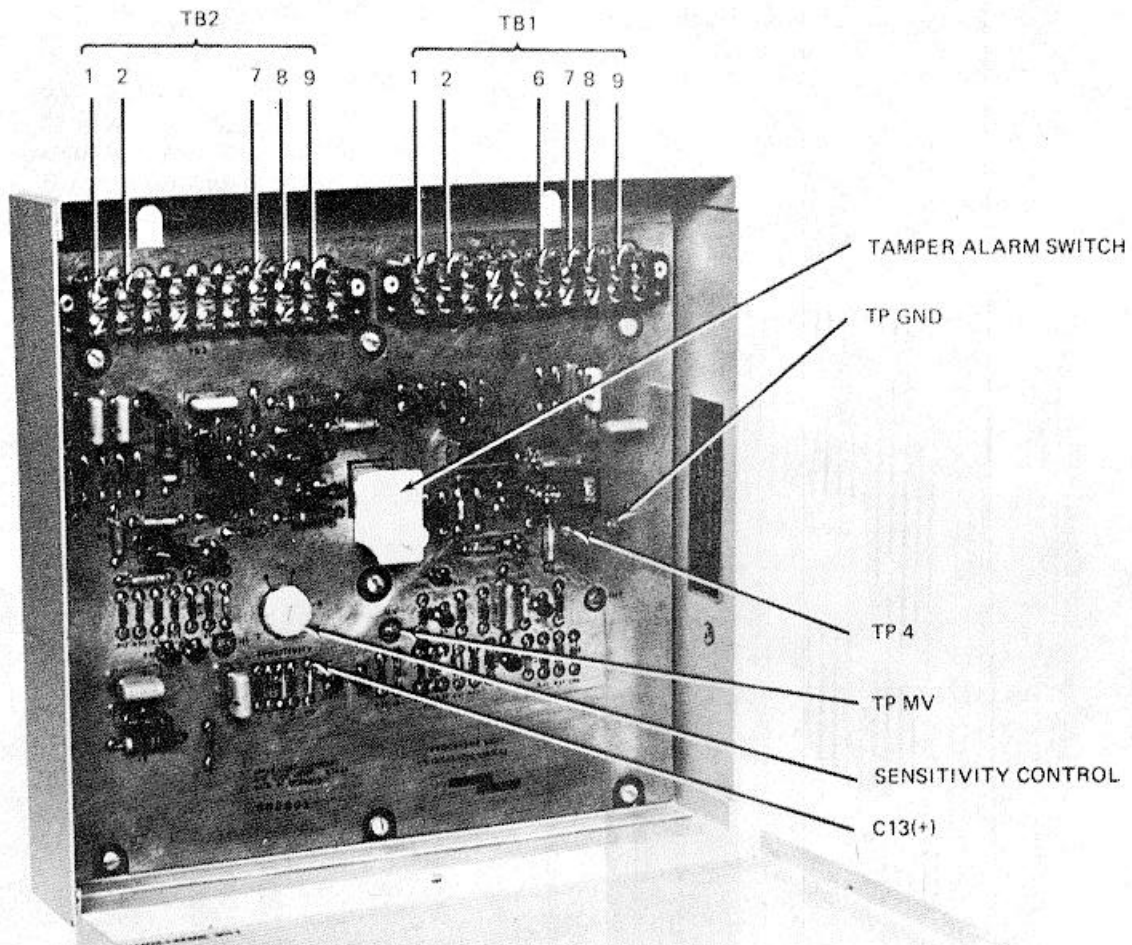

Figure 5-1. Processor, Vibration Signal with Troubleshooting Test Points

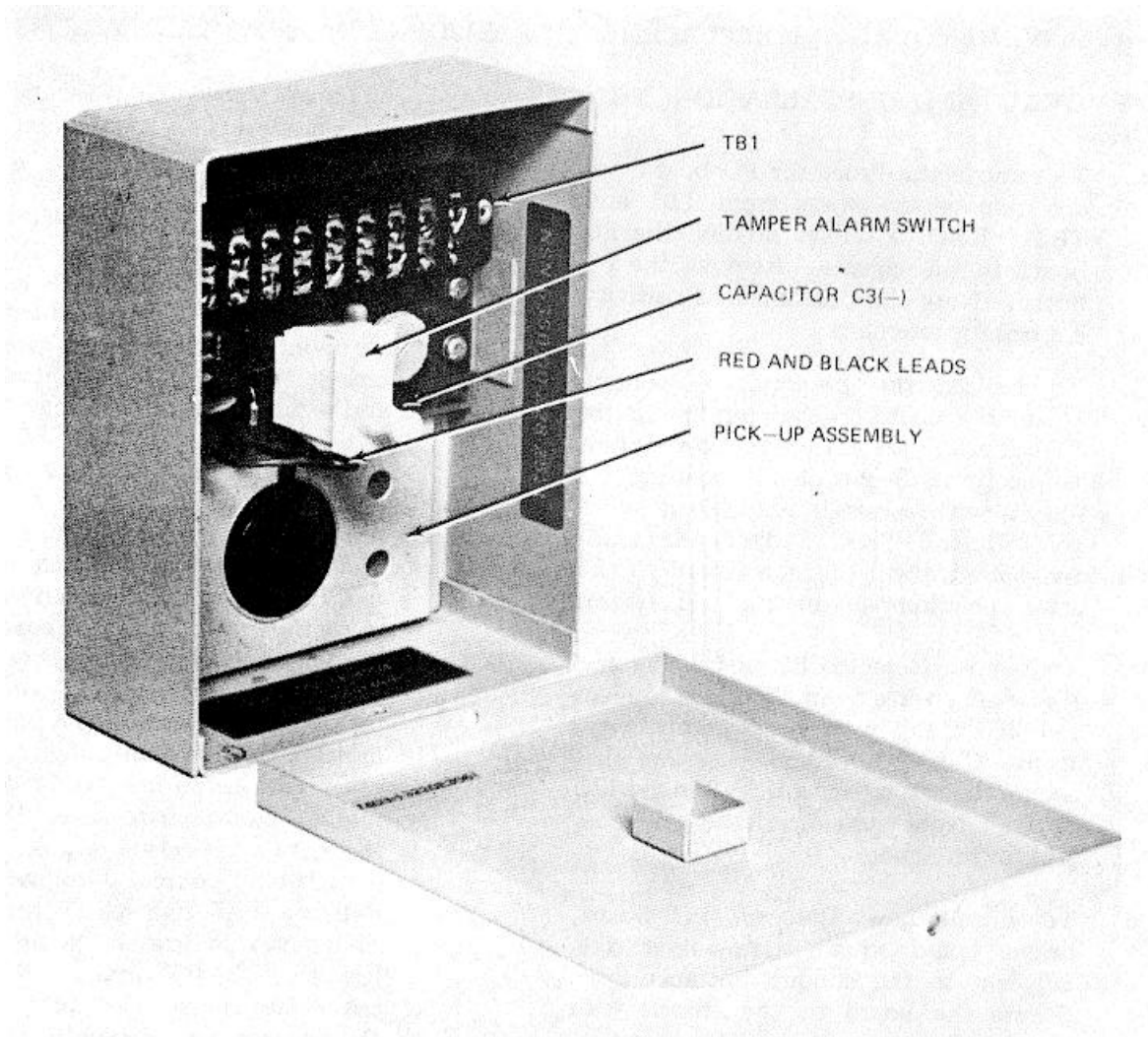

Figure 5-2. Detector, Vibration Signal with Troubleshooting Test Points

### Section III. GENERAL MAINTENANCE

**5-4. MAINTENANCE ACTION.** The extent of direct and general support maintenance is governed by the Maintenance Allocation Chart (MAC), Appendix B. The MAC provides for on-site test and replacement of the PC boards in both the Processor and Detector and the vibration pick-up assembly in

the Detector. On-site adjustment is made on the gain control in the Detector and the sensitivity control in the Processor. Inspection only is made on the chassis. Periodic testing of the Vibration Sensor is not scheduled because the J-SIIDS is maintained in continuous operation.

### Section IV. REMOVAL AND REPLACEMENT OF MAJOR COMPONENTS AND ASSEMBLIES

#### 5-5. REMOVAL AND INSTALLATION PROCEDURES.

- a. To remove the Processor PC board, tag and remove the wires from TB1 and TB2. Remove screws holding the PC board in the chassis. Remove the PC board. Note the position of sensitivity control for reference.
- b. To replace the processor PC board, orient the board so that terminal strips TB1 and TB2 are adjacent to the conduit connections. Secure the PC board to the chassis with screws. Attach the wires to TB1 and TB2. Adjust the sensitivity control on the new board to the same position as on the old board.
- c. To remove Detector PC board, tag and disconnect wires from TB1. Disconnect red and black pick up assembly wires from PC board. Remove screws that secure board to chassis. Remove PC board. Note position of the gain control for reference.
- d. To install new Detector PC board, orient board so the terminal strip is adjacent to the conduit entrance hole. Secure the board to the chassis with screws. Connect wires to TB1, and connect red and black pick-up assembly wires to the marked terminals on the board. Adjust the gain control on the new board to the same position as on the old board.
- e. To remove pick-up assembly, disconnect red and black wires from PC board.
- f. Remove screws that secure assembly to mounting surface, and remove assembly.
- f. To install new pick-up assembly, orient assembly so that red and black wires are toward PC board. Tilt assembly so that edge nearest PC board can be slipped under PC board. Insert assembly into chassis, flat against mounting surface, and secure it with four screws.
- g. After replacement of major components or assemblies during troubleshooting, test the VS for proper operation. Ensure that the key-operated switch on the Control Unit is in the access position. Remove the Processor chassis cover and pull the TAS plunger all the way out. Set multimeter to ohms and connect leads to TB1-6 and TB1-2. The meter should indicate 2, 000 ohms or less. Slowly open the cover on the first Detector. While the cover flanges are still engaged, the meter indication should change to over 100,000 ohms. Remove the cover. Pull the TAS plunger all the way out. The meter indication should change to less than 2, 000 ohms. Replace the cover. Repeat the test on the remaining Detectors. Use a straightedge across the Processor chassis to hold the TAS plunger down. The meter should indicate 2, 000 ohms or less. Slowly raise the straightedge. After the TAS plunger moves 1/4 inch (0.635 cm) or less, the meter indication should change to over 100, 000 ohms. Disconnect the wire from TB1-1. Set multimeter to ohms

and connect the leads to TB1-1 and TB1-2. The meter should indicate about 110 ohms. At each Detector in turn, tap on the mounting surface or the conduit next to the Detector. After each series

of taps the meter indication should change to over 100,000 ohms and then, after a few seconds, should drop back to about 110 ohms. Install cover.

**5-23/(5-24 blank)**

**CHAPTER 6**

**REPAIR OF THE VIBRATION SENSOR**

This chapter is not applicable to this equipment.

**6-1/(6-2 blank)**

APPENDIX A

REFERENCES

- |   |   |
|---|---|
| 1. DEMOLITION<br>TM 750-244-3   | Procedures for Destruction of Equipment to Prevent Enemy Use                  |
| 2. FIRE PROTECTION<br>TB5-4200-200-10   | Hand Portable Fire Extinguishers Approved for Army Users                      |
| 3. MAINTENANCE<br>DA Pamphlet 738-750   | The Army Maintenance Management System  |
| 4. TRI-SERVICE MANUALS  |   |
| DMWR 5-6350-264<br>NAVELEX EE181-AA-MMD-010/E121<br>J-SIIDS MWR<br>AIR FORCE T.O. 31S9-4-1-213          | Depot Maintenance Work Requirement  |
| TM 5-6350-264-14-1<br>NAVELEX EE181-AA-INM-020/E121<br>J-SIIDS INS<br>AIR FORCE T.O. 31S9-4-1-201       | Installation, Operation and Checkout Procedures                               |
| TM 5-6350-264-14&P-2<br>NAVELEX EE181-AA-OMI-030/E121<br>RT1161 M9443<br>AIR FORCE T.O. 31S9-2FSS9-1-2  | Transceiver, Ultrasonic Signal and Processor, Ultrasonic Motion Signal        |
| TM 5-6350-264-14&P-3<br>NAVELEX EE181-AA-OMI-040/E121<br>R1860 M9443<br>AIR FORCE T.O. 31S9-2FSS9-1-3   | Receiver Passive Signal, Ultrasonic and Processor, Passive Signal, Ultrasonic |
| TM 5-6350-264-14 & P-4<br>NAVELEX EE181-AA-OMI-050/E121<br>DT546 M9442<br>AIR FORCE T.O. 31S9-2FSS9-1-4 | Detector, Vibration Signal and Processor, Vibration Signal                    |
| TM 5-6350-264-14&P-5<br>NAVELEX EE181-AA-OMI-060/E121<br>SA-1955<br>AIR FORCE T.O. 31S9-2FSS9-1-5       | Switch, Balanced Magnetic   |
| TM 5-6350-264-14&P-6<br>NAVELEX EE181-AA-OMI-070/E121<br>DT-545<br>AIR FORCE T.O. 31S9-2FSS9-1-6        | Sensor, Grid Wire   |
| TM 5-6350-264-14&P-7<br>NAVELEX EE181-AA-OMI-080/E121<br>DT-548<br>AIR FORCE T.O. 31S9-2FSS9-1-7        | Sensor, Capacity Proximity  |



TM 5-6350-264-14&P-8  
NAVELEX EE181-AA-OMI-090/E121  
SA-1954  
AIR FORCE T.O. 31S9-2FSS9-1-8

Switch, Alarm Latching

TM 5-6350-264-14&P-9  
NAVELEX EE181-AA-OMI-100/E121  
DZ-204  
AIR FORCE T.O. 31S9-2FSS9-1-9

Alarm, Audible

TM 5-6350-264-14&P-10  
NAVELEX EE181-AA-OMI-110/E121  
C-9412  
AIR FORCE T.O. 31S9-2FSS9-1-10

Control Unit, Alarm Set

TM 5-6350-264-14&P-11  
NAVELEX EE181-AA-OMI-120/E121  
C-7359-60-1  
AIR FORCE T.O. 31S9-2FSS9-1-11

Cabinet, Monitor, Type A, Type B, Type C and Monitor  
Module, Status, Monitor Module, Alarm

TM 5-6350-264-14&P-12  
NAVELEX EE181-AA-OMI-130/E121  
R1861-T1257  
AIR FORCE T.O. 31S9-2FSS9-1-12

Receiver, Data and Transmitter, Data

TM 5-6350-264-14&P-13  
NAVELEX EE181-AA-OMI-140/E121  
DT-547  
AIR FORCE T.O. 31S9-2FSS9-1-13

Sensor, Magnetic Weapons (DT-547)

TB 5-6350-264  
NAVELEX EE181-AB-OMI-010/E121  
J-SIIDS  
AIR FORCE T.O. 31S9-4-1-111

Selection and Application of Joint Services Interior  
Intrusion Detection System

PAINTING  
SB 11-573

Painting and Preservation Supplies Available for Field  
Use for Electronic Equipment

TM 43-0139

Painting Instructions for Field Use

RADIOACTIVE MATERIAL  
TB 43-0141

Instructions for Safe Handling, Maintenance, Storage,  
and Disposal of Radio-active Commodities

SHIPMENT AND STORAGE  
TM 740-90-1

Administrative Storage of Equipment

## APPENDIX B

### MAINTENANCE ALLOCATION CHART

#### Section I. INTRODUCTION

##### B-1. GENERAL.

- a. This section provides a general explanation of all maintenance and repair functions authorized at various maintenance levels.
- b. Section II designates overall responsibility for the performance of maintenance functions on the identified end item or component. The implementation of the maintenance functions upon the end item or component will be consistent with the assigned maintenance functions.
- c. Section III lists the special tools and test equipment required for each maintenance function as referenced from section II.
- d. Section IV contains supplemental instructions or explanatory notes for a particular maintenance function. (Not Applicable)
- d. Adjust. To maintain, within prescribed limits, by bringing into proper or exact position, or by setting the operating characteristics to specified parameters.
- e. Align. To adjust specified variable elements of an item to bring about optimum or desired performance.
- f. Calibrate. To determine and cause corrections to be made, or to be adjusted on instruments for test, measuring and diagnostic equipments used in precision measurement. Consists of comparisons of two instruments, one of which is a certified standard of known accuracy, to detect and adjust any discrepancy in the accuracy of the instrument being compared.
- g. Install. The act of emplacing, seating, or fixing into position an item, part, or module in a manner to allow the proper functioning of an equipment or system.
- h. Replace. The act of substituting a serviceable like part, subassembly, or module for an unserviceable counterpart.

##### B-2. MAINTENANCE FUNCTIONS. Maintenance functions are defined as follows:

- a. Inspect. To determine the serviceability of an item by comparing its physical, mechanical and/ or electrical characteristics with established standards through examination.
- b. Test. To verify serviceability and detect incipient failure by measuring the mechanical or electrical characteristics of an item and comparing those characteristics with prescribed standards.
- c. Service. Operations required periodically to keep an item in proper operating condition, i.e., to clean, to preserve, to drain, to paint, or to replenish fuel, lubricants, hydraulic fluids, or compressed air supplies.
- i. Repair. The application of maintenance services (inspect, test, service, adjust, align, calibrate, or replace) or other maintenance actions (welding, grinding, riveting, straightening, facing, remachining, or resurfacing) to restore serviceability to an item by correcting specific damage, fault, malfunction, or failure in a part, subassembly, module, end item or system.
- j. Overhaul. That maintenance effort (service/ actions) necessary to restore an item to a completely serviceable/operational condition as prescribed by maintenance standards (i.e., DMWR) in appropriate technical publications. Overhaul is normally the highest degree of maintenance performed by the Army. Overhaul does not normally return an item to like new condition.

k. Rebuild. Consists of those services/actions necessary for the restoration of unserviceable equipment to a like new condition in accordance with original manufacturing standards. Rebuild is the highest degree of materiel maintenance applied to Army equipment. The rebuild operation includes the act of returning to zero those age measurements (hours/miles, etc.) considered in classifying Army equipments/components.

**B-3. COLUMN ENTRIES.**

a. Column 1, Group Number. Column 1 lists group numbers, the purpose of which is to identify components, assemblies, subassemblies, and modules with the next higher assembly.

b. Column 2, Component/Assembly. Column 2 contains the names of components, assemblies, subassemblies, and modules for which maintenance is authorized.

c. Column 3, Maintenance Function. Column 3 lists the functions to be performed on the item listed in column 2.

d. Column 4, Maintenance Level. Column 4 specifies, by the listing of a "work time" figure in the appropriate subcolumn (s), the lowest level of maintenance authorized to perform the function listed in column 3. This figure represents the active time required to perform the maintenance function at the indicated level of maintenance. If the number of complexity of the tasks within the listed maintenance function varies at different

maintenance levels, appropriate "work time" figures will be shown for each level. The number of man-hours specified by the "work time" figure represents the average time required to restore an item (assembly, subassembly, component, module, end item, or system) to a serviceable condition under typical field operating conditions. This time includes preparation time, troubleshooting time, and quality assurance/quality control time in addition to the time required to perform the specific tasks identified for the maintenance functions authorized in the maintenance allocation chart. The symbol designations for the various maintenance levels are as follows:

- C..... Operator or crew
- O..... Organization maintenance
- F..... Direct support maintenance
- H..... General support maintenance
- D..... Depot maintenance

e. Column 5, Tools and Equipment. Column 5 specifies, by code, those common tool sets (not individual tools) and special tools, test, and support equipment required to perform the designated function.

f. Column 6, Remarks. Column 6 contains an alphabetic code which leads to the remark in section IV, Remarks, which is pertinent to the item opposite the particular code.

**Section II. MAINTENANCE ALLOCATION CHART**  
 for

**Vibration Signal Detector (DT-546) and Vibration Signal Processor (MX-9442)**

(1) Group number	(2) Component/assembly	(3) Maint. function	(4) Maint. level					(5) Tool/ equipment	(6) Remarks
			C	O	F	H	D		
01	Vibration Signal Detector								
	Printed Wiring Board Assy	Test Replace			0.5 1.0			1	
	Vibration Pickup Assy	Test Replace			0.5 0.5			1	
02	Gain Control Enclosure	Adjust Inspect	0.3		0.5				
	Vibration Signal Processor								
	Printed Wiring Board Assy	Test Replace			0.5 1.0			1	
	Sensitivity Control	Adjust			0.5				
	Enclosure	Inspect	0.3						
		<b>Change 1 B-3</b>							

**Section III. TOOL AND TEST EQUIPMENT REQUIREMENTS**

**for**

**Vibration Detection (DT-546) and Vibration Signal Processor (MX-9442)**

(1)	(2)	(3)	(4)	(5)
Reference code	Maintenance category	Nomenclature	National stock number (NSN)	Tool number
1.	F	Multimeter	6625-00-019-0815	Vom

**Section IV. REMARKS**

**Maintenance Allocation Chart**

Reference code	Remarks

**B-5/(B-6 blank)**

## APPENDIX C

### ORGANIZATIONAL, DIRECT SUPPORT AND GENERAL SUPPORT MAINTENANCE REPAIR PARTS AND SPECIAL TOOLS LIST

#### Section I. INTRODUCTION

##### 1. Scope.

This manual lists and authorizes repair parts; special tools; special test, measurement, and diagnostic equipment (TMDE); and other special support equipment required for performance of organizational, direct support, and general support maintenance of the Vibration Sensor. It authorizes the requisitioning, issue, and disposition of spares, repair parts and special tools as indicated by the Source, Maintenance and Recoverability (SMR) codes.

##### 2. General.

This Repair Parts and Special Tools List is divided into the following sections:

a. Section II. Repair Parts List. A list of spares and repair parts authorized by this RPSTL for use in the performance of maintenance. The list also includes parts which must be removed for replacement of the authorized parts. Parts lists are composed of functional groups in ascending alphanumeric sequence, with the parts in each group listed in ascending figure and item number sequence. Bulk materials are listed in NSN sequence.

b. Section III. Special Tools List. A list of special tools, special TMDE, and other special support equipment authorized by this RPSTL for the performance of maintenance.

c. Section IV. National Stock Number and Part Number Index. A list, in National Item Identification Number (NIIN) sequence, of all National Stock Numbers (NSN) appearing in the listings, followed by a list in alphanumeric sequence of all part numbers appearing in the listings. National stock numbers and part numbers are cross-referenced to each illustration figure and item number appearance.

##### 3. Explanation of Columns.

a. Illustration (Column (1)). This column is divided as follows:

(1) ((a) FIG NO.) Figure Number. Indicates the figure number illustrating an exploded view of a functional group.

(2) ((b) ITEM NO.). Indicates the number used to identify items called out in the illustration.

**Change 1 C-1**

b. SMR CODE (Column (2)). The Source, Maintenance, and Recoverability (SMR) code is a 5-position code containing supply/requisitioning information, maintenance category authorization criteria, and disposition instructions, as shown in the following breakout:

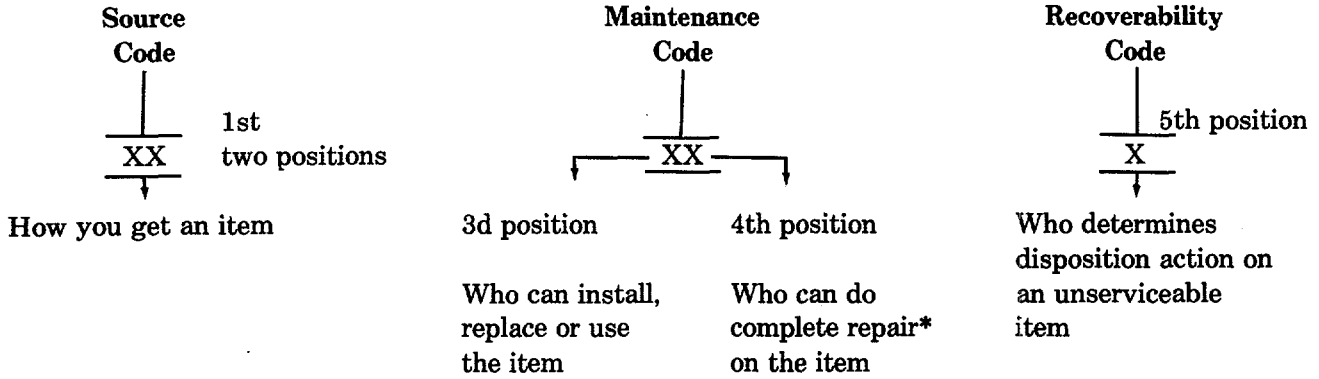

\*Complete Repair: Maintenance capacity, capability, and authority to perform all the corrective maintenance tasks of the "Repair" function in a use/user environment in order to restore serviceability to a failed item.

(1) Source Code. The source code tells you how you get an item needed for maintenance, repair, or overhaul of an end item/equipment. Source codes are always the first two positions of the SMR code. Explanations of source codes follow:

<b>Code</b>	<b>Explanation</b>
<div style="border: 1px solid black; padding: 5px; display: inline-block; width: 40px;">           PA PB PC PD PE PF PG         </div>	<p>Stocked items; use the applicable NSN to request/requisition items with these source codes. They are authorized to the category indicated by the code entered in the 3d position of the SMR code.</p> <hr style="border-top: 1px dotted black;"/>
<div style="border: 1px solid black; padding: 5px; display: inline-block; width: 40px;">           KD KF KB         </div>	<p>Items with these codes are not to be requested/requisitioned individually. They are part of a kit which is authorized to the maintenance category indicated in the 3d position of the SMR code. The complete kit must be requisitioned and applied.</p> <hr style="border-top: 1px dotted black;"/>
<div style="border: 1px solid black; padding: 5px; display: inline-block; width: 150px;">           MO—Made at org/ AVUM category            MF—Made at DS/ AVUM category            MH—Made at GS category            ML—Made at Specialized Repair Activity (SRA)            MD—Made at Depot         </div>	<p>Items with these codes are not to be requested/requisitioned individually. They must be made from bulk material which is identified by NSN in the Description column and listed in the Bulk Material group in the repair parts list in this manual. If the item is authorized to you by the 3d position code of the SMR code, but the source code indicates it is made at a higher category, order the item from the higher category of maintenance.</p> <hr style="border-top: 1px dotted black;"/>



**Code**

**Explanation**

AO —Assembled by org/AVUM category  
 AF —Assembled by DS/AVUM category  
 AH —Assembled by GS category  
 AL —Assembled by SRA  
 AD —Assembled by Depot

Items with these codes are not to be requested/requisitioned individually. The parts that make up the assembled item must be requisitioned or fabricated and assembled at the category of maintenance indicated by the source code. If the 3d position code of the SMR code authorizes you to replace the item, but the source code indicates the item is assembled at a higher category, order the item from the higher category of maintenance.

.....

- XA-** Do not requisition an "XA"-coded item. Order its next higher assembly. (Also, refer to the NOTE below.)
- XB-** If an "XB" item is not available from salvage, order it using the FSCM and part number given.
- XC-** Installation drawing, diagram, instruction sheet, field service drawing, that is identified by manufacturer's part number.
- XD-** Item is not stocked. Order an "XD"-coded item through normal supply channels using the FSCM and part number given, if no NSN is available.

**NOTE**

Cannibalization or controlled exchange, when authorized, may be used as a source of supply for items with the above source codes, except for those source coded "XA" or those aircraft support items restricted by requirements of AR 700-42.

(2) Maintenance Code. Maintenance codes tell you the category(s) of maintenance authorized to USE and REPAIR support items. The maintenance codes are entered in the third and fourth positions of the SMR Code as follows:

(a) The maintenance code entered in the third position tells you the lowest maintenance category authorized to remove, replace, and use an item. The maintenance code entered in the third position will indicate authorization to one of the following categories of maintenance.

**Code**

**Application/Explanation**

- C** - Crew or operator maintenance done within organizational or aviation unit maintenance.
- O** - Organizational or aviation unit category can remove, replace, and use the item.
- F** - Direct support or aviation intermediate category can remove, replace, and use the item.
- H** - General support category can remove, replace, and use the item.
- L** - Specialized repair activity can remove, replace, and use the item.
- D** - Depot category can remove, replace, and use the item.

**Change 1 C-3**

(b) The maintenance code entered in the fourth position tells you whether or not the item is to be repaired and identifies the lowest maintenance category with the capability to do complete repair (i.e., perform all authorized repair functions). (NOTE: Some limited repair may be done on the item at a lower category of maintenance, if authorized by the Maintenance Allocation Chart (MAC) and SMR codes.) This position will contain one of the following maintenance codes.

<b>Code</b>	<b>Application/Explanation</b>
<b>O</b>	- Organizational or aviation unit is the lowest category that can do complete repair of the item.
<b>F</b>	- Direct support or aviation intermediate is the lowest category that can do complete repair of the item.
<b>H</b>	- General support is the lowest category that can do complete repair of the item.
<b>L</b>	- Specialized repair activity (designate the specialized repair activity) is the lowest category that can do complete repair of the item.
<b>D</b>	Depot is the lowest category that can do complete repair of the item.
<b>Z</b>	- Nonreparable. No repair is authorized.
<b>B</b> authorized	- No repair is authorized. (No parts or special tools are for the maintenance of a "B" coded item.) However, the item may be reconditioned by adjusting, lubricating, etc., at the user level.

(3) Recoverability Code. Recoverability codes are assigned to items to indicate the disposition action on unserviceable items. The recoverability code is entered in the fifth position of the SMR Code as follows:

<b>Recoverability Codes</b>	<b>Definition</b>
<b>Z</b>	- Nonreparable item. When unserviceable, condemn and dispose of the item at the category of maintenance shown in 3d position of SMR Code.
<b>O</b>	- Repairable item. When uneconomically repairable, condemn and dispose of the item at organizational or aviation unit category.
<b>F</b>	- Repairable item. When uneconomically repairable, condemn and dispose of the item at the direct support or aviation intermediate category.
<b>H</b>	- Repairable item. When uneconomically repairable, condemn and dispose of the item at the general support category.
<b>D</b>	- Repairable item. When beyond lower category repair capability, return to depot. Condemnation and disposal of item not authorized below depot category.

- L** - Reparable item. Condemnation and disposal not authorized below specialized repair activity.
- A** - Item requires special handling or condemnation procedures because of specific reasons (i.e., precious metal content, high dollar value, critical material, or hazardous material). Refer to appropriate manuals/directives for specific instructions.

c. National Stock Number (Column (3)). Lists the National Stock Number (NSN) assigned to the item. Use the NSN for requests/requisitions.

d. FSCM (Column (4)). The Federal Supply Code for Manufacturer (FSCM) is a 5-digit numeric code which is used to identify the manufacturer, distributor, or Government agency, etc., that supplies the item.

e. Part Number (Column (5)). Indicates the primary number used by the manufacturer (individual, company, firm, corporation, or Government activity), which controls the design and characteristics of the item by means of its engineering drawings, specifications standards, and inspection requirements to identify an item or range of items.

#### NOTE

When you use an NSN to requisition an item, the item you receive may have a different part number from the part ordered, but go ahead and use or furnish it as the replacement part.

f. Description (Column (6)). This column includes the following information:

(1) The Federal item name and, when required, a minimum description to identify the item.

(2) The physical security classification of the item is indicated by the parenthetical entry (insert applicable physical security classification abbreviation, e.g., Phy Sec C1 (C) - Confidential, Phy Sec C1 (S) - Secret, Phy Sec C1 (T) - Top Secret).

(3) Items that are included in kits and sets are listed below the name of the kit or set.

(4) Spare/repair parts that make up an assembled item are listed immediately following the assembled item line entry.

(5) NSN's for bulk materials are referenced in the description column in the line item entry for the item to be manufactured/fabricated.

(6) When the part to be used differs between serial numbers of the same model, the effective serial numbers are shown as the last line of the description.

(7) The USABLE ON CODE, when applicable (see paragraph 4, Special Information).

(8) In the Special Tools List section, the Basis of Issue (BOI) appears as the last line(s) in the entry for each special tool, special TMDE, and other special support equipment. When density of equipments supported exceeds density spread indicated in the basis of issue, the total authorization is increased proportionately.

g. U/M (Column (7)). The Unit of Measure (U/M) indicates the measure (e.g., foot, gallon, pound) or count (e.g., each, dozen, gross) of a listed item. A two-character alpha code (e.g., FT, GL, LB, EA, DZ, GR) appears in this column to indicate the measure or count. If the U/M code appearing in this column differs from the Unit of issue (U/I) code listed in the Army Master Data File (AMDF), request the lowest U/I that will satisfy your needs.

h. QTY INC IN UNIT (Column (8)). The Quantity Incorporated In Unit (QTY INC IN UNIT) indicates the quantity of the item used in the breakout shown on the illustration figure, which is prepared for a functional group, subfunctional group, or an assembly. A "V" appearing in this column in lieu of a quantity indicates that no specific quantity is applicable (e.g., shims, spacers).

#### 4. Special Information.

a. The "USABLE ON CODE" title appears in the lower right corner of column (6), Description. Usable on codes are shown in the right-hand margin of the description column. Uncoded items are applicable to all models. Identification of the usable on codes used in this publication are:

<u>Code</u>	<u>Used On</u>
CWK	DT-546/FSS-9(V)
CWL	MX-9442/FSS-9(V)

b. Line item entries for repair parts kits and sets appear as the last entries in the repair parts listing for the figure in which their parts are listed as repair parts.

#### 5. How to Locate Repair Parts.

a. When National Stock Number or Part Number is Not Known:

(1) First. Using the table of contents, determine the functional group or subfunctional group to which the item belongs. This is necessary since figures are prepared for functional groups and subfunctional groups, and listings are divided into the same groups.

(2) Second. Find the figure covering the functional group or subfunctional group to which the item belongs.

(3) Third. Identify the item on the figure and note the item number of the item.

(4) Fourth. Refer to the Repair Parts List for the figure to find the line item entry for the item number noted on the figure.

b. When National Stock Number or Part Number is Known:

(1) First. Using the Index of National Stock Numbers and Part Numbers, find the pertinent National stock number or part number. The NSN index is in National Item Identification Number (NIIN)\* sequence. The part numbers in the Part Number index are listed in ascending alphanumeric sequence. Both indexes cross-reference you to the illustration figure and item number of the item you are looking for.

NSN

\*The NIIN consists of the last 9 digits of the NSN (i.e., 5305-01-674-1467).

NIIN

(2) Second. After finding the figure and item number, verify that the item is the one you're looking for, then locate the item number in the repair parts list for the figure.

6. Abbreviations.

<u>Abbreviations</u>	<u>Explanation</u>
cd-or	Cadmium-ore
zn-pltd	zinc-plated
MOD	Model
opng	opening
NIIN	National Item Identification Number (consists of the last 9 digits of the NSN)
RPSTL	Repair Parts and Special Tools List

**Change 1 C-7**

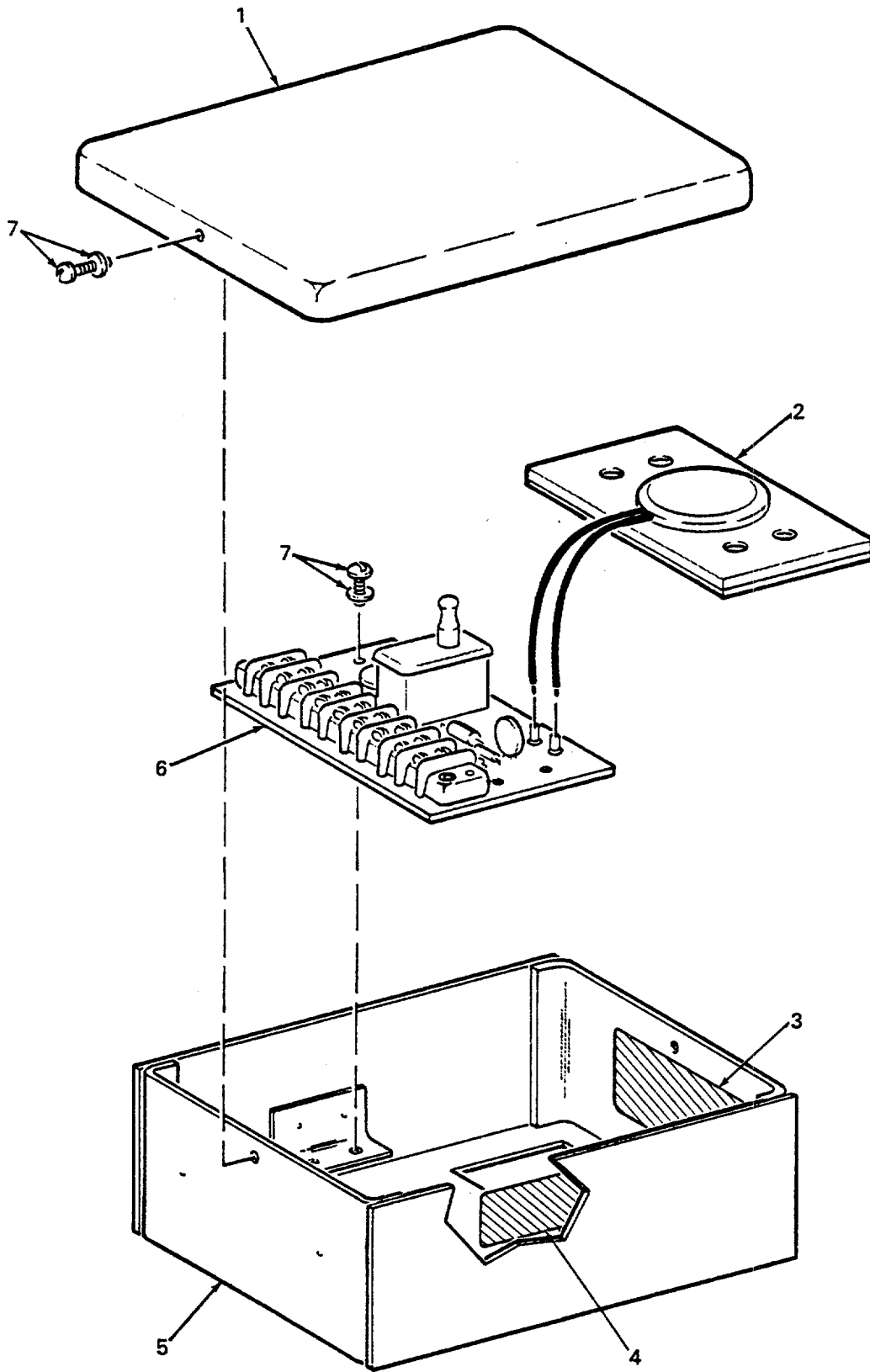

Figure C-1. Vibration Signal Detector DT-546/FSS-9(V)

Change 1 C-8

**Section II. REPAIR PARTS LIST**

(1) ILLUSTRATION QTY		(2) SMRS	(3) NATIONAL	(4)	(5)	(6) DESCRIPTION	(7)	(8)
(A) INC FIG.	(B) ITEM	CODE	STOCK NUMBER	FSCM	PART NUMBER	USABLE ON CODE	U/M	UNIT
						GROUP 01 VIBRATION SIGNAL DETECTOR		
C-1	1	XSFZZ		97403	13220E3061	COVER, DETECTOR..... CWK	EA	1
C-1	2	PAFZZ	6350-00-368-8188	97403	13220E3064	SENSOR, VIBRATIGN.....CWK	EA	1
C-1	3	XDFZZ		97403	13220E30b0	PLATE..... CWK	EA	1
C-1	4	XDFZZ		97403	13220E3065	PLATE ..... CWK	EA	1
C-1	5	XBFZZ	6350-00-36U-7759	81349	13220E3062	CHASSIS, ELECTRICAL ..... CWK	EA	1
C-1	6	PAFZZ	6350-00-345-8391	97403	1322013063	CIRCUIT CARD ASSEMB ..... CWK	EA	1
C-1	7	XBFZZ		91403	13220E2997	SCREW, ASSEMBLED ..... CWK	EA	6
					<b>Change 1 C-9</b>			

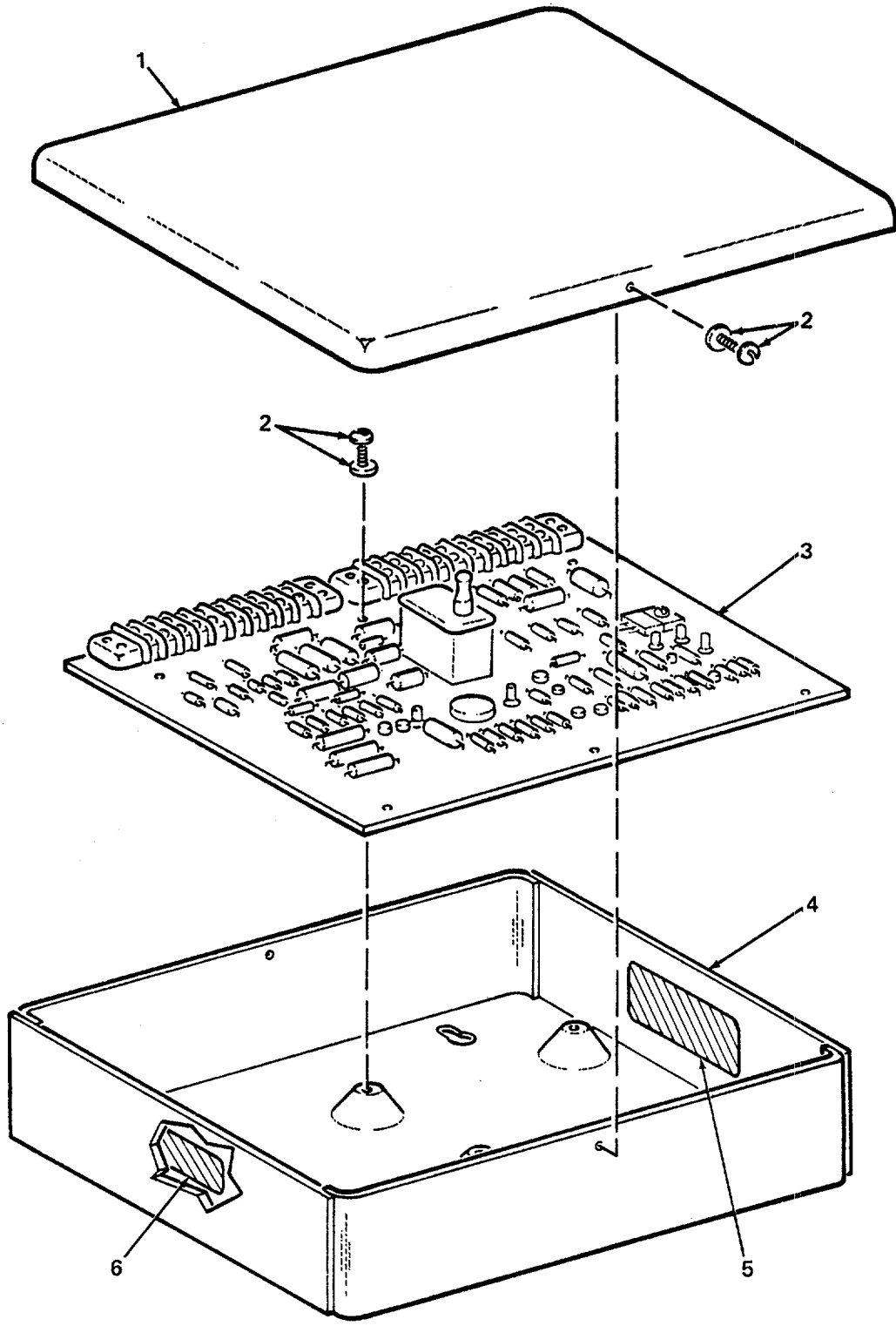

Figure C-2. Vibration Signal Processor MX-9442/FSS-9(V)



(1) ILLUSTRATION QTY		(2) SMRS	(3) NATIONAL	(4)	(5)	(6) DESCRIPTION	(7)	(8)
(A) INC FIG.	(B) ITEM	CODE	STOCK NUMBER	FSCM	PART NUMBER	USABLE ON CODE	U/M	UNIT
						GROUP 02 VIBRATIUN SIGNAL PROCESSOR		
C-2	1	XIFZZ	6350-00-140-0787	97403	1322E3011	OVER PRCESSOR ..... CWL	EA	1
C-2	2	XAZZ		97403	13220E2997	SCREW, ASSEMBLED ..... CWL	EA	9
C-2	3	PAFZZ	6350-00-345-8397	97403	13220E3013	CIRCUIT CARD ASSEM ..... CWL	EA	1
C-2	4	XBFZZ		97433	13220E3012	CHASSIS, Electrical..... CWL	EA	1
C2	5	XAFZZ		97403	13220E3010	PLATE ..... CWL	EA	1
C2	6	XAFZZ		97403	13220E3014	PLATE ..... CWL	EA	1
<b>Change 1 C-11</b>								

**Section III. SPECIAL TOOLS LIST**

This section is not applicable.

**Section IV. NATIONAL STOCK NUMBER AND PART NUMBER INDEX**

STOCK NUMBER	FIGURE NO.	ITEM NO.	STOCK NUMBER	FIGURE NO.	ITEM NO.
6350-00-140-0787	C-2	1	6350-00-360-7759	C-1	5
63S0-00-345-8391	C-1	2	6350-00-368-8188	C-1	2
6350-00-345-8397	C-2	3			

FSCM	PART NUMBER	FIGURE NO.	ITEM NO.	FSCM	PART NUMBER	FIGURE NO.	ITEM NO.
97403	13220E2997	C-1	7	97403	13220E3060	C-1	3
97403	13220E2997	C-2	2	97403	13220E3061	C-1	1
97403	13220E3010	C-2	5	81349	13220E3062	C-1	5
97403	13220E3011	C-2	1	97403	13220E3063	C-1	6
97403	13220E3012	C-2	4	97433	13220E3064	C-1	2
97403	13220E3013	C-2	3	97403	13220E3065	C-1	4
97403	13220E3014	C-2	6				

U.S. GOVERNMENT PRINTING OFFICE: 1986 652-126/20215

**Change 1 C-12**

By Order of the Secretaries of the Army, the Navy, and the Air Force:

Official:

E. C. MEYER  
*General, United States Army*  
*Chief of Staff*

ROBERT M. JOYCE  
*Brigadier General, United States Army*  
*The Adjutant General*

H. D. ARNOLD  
*Rear Admiral, United States Navy*  
*Commander, Naval Electronic*  
*Systems Command*

Official:

CHARLES A. GABRIEL, *General, USAF*  
*Chief of Staff*

JAMES P. MULLINS  
*General, USAF, Commander, Air Force*  
*Logistics Command*

DISTRIBUTION:

To be distributed in accordance with DA Form 12-25A, Operator Maintenance requirements for Intrusion Detection.

\*U.S. GOVERNMENT PRINTING OFFICE: 1982-564029/1262

RECOMMENDED CHANGES TO EQUIPMENT TECHNICAL PUBLICATIONS



THEN...JOT DOWN THE  
DOPE ABOUT IT ON THIS FORM.  
CAREFULLY TEAR IT OUT, FOLD IT  
AND DROP IT IN THE MAIL.

SOMETHING WRONG WITH PUBLICATION

FROM: (PRINT YOUR UNIT'S COMPLETE ADDRESS)

DATE SENT

PUBLICATION NUMBER

PUBLICATION DATE

PUBLICATION TITLE

BE EXACT PIN-POINT WHERE IT IS

PAGE  
NO.

PARA-  
GRAPH

FIGURE  
NO.

TABLE  
NO.

IN THIS SPACE, TELL WHAT IS WRONG  
AND WHAT SHOULD BE DONE ABOUT IT.

TEAR ALONG PERFORATED LINE

PRINTED NAME, GRADE OR TITLE AND TELEPHONE NUMBER

SIGN HERE

# The Metric System and Equivalents

## Linear Measure

1 centimeter = 10 millimeters = .39 inch  
 1 decimeter = 10 centimeters = 3.94 inches  
 1 meter = 10 decimeters = 39.37 inches  
 1 dekameter = 10 meters = 32.8 feet  
 1 hectometer = 10 dekameters = 328.08 feet  
 1 kilometer = 10 hectometers = 3,280.8 feet

## Weights

1 centigram = 10 milligrams = .15 grain  
 1 decigram = 10 centigrams = 1.54 grains  
 1 gram = 10 decigrams = .035 ounce  
 1 dekagram = 10 grams = .35 ounce  
 1 hectogram = 10 dekagrams = 3.52 ounces  
 1 kilogram = 10 hectograms = 2.2 pounds  
 1 quintal = 100 kilograms = 220.46 pounds  
 1 metric ton = 10 quintals = 1.1 short tons

## Liquid Measure

1 centiliter = 10 milliliters = .34 fl. ounce  
 1 deciliter = 10 centiliters = 3.38 fl. ounces  
 1 liter = 10 deciliters = 33.81 fl. ounces  
 1 dekaliter = 10 liters = 2.64 gallons  
 1 hectoliter = 10 dekaliters = 26.42 gallons  
 1 kiloliter = 10 hectoliters = 264.18 gallons

## Square Measure

1 sq. centimeter = 100 sq. millimeters = .155 sq. inch  
 1 sq. decimeter = 100 sq. centimeters = 15.5 sq. inches  
 1 sq. meter (centare) = 100 sq. decimeters = 10.76 sq. feet  
 1 sq. dekameter (are) = 100 sq. meters = 1,076.4 sq. feet  
 1 sq. hectometer (hectare) = 100 sq. dekameters = 2.47 acres  
 1 sq. kilometer = 100 sq. hectometers = .386 sq. mile

## Cubic Measure

1 cu. centimeter = 1000 cu. millimeters = .06 cu. inch  
 1 cu. decimeter = 1000 cu. centimeters = 61.02 cu. inches  
 1 cu. meter = 1000 cu. decimeters = 35.31 cu. feet

## Approximate Conversion Factors

To change	To	Multiply by	To change	To	Multiply by
inches	centimeters	2.540	ounce-inches	newton-meters	.007062
feet	meters	.305	centimeters	inches	.394
yards	meters	.914	meters	feet	3.280
miles	kilometers	1.609	meters	yards	1.094
square inches	square centimeters	6.451	kilometers	miles	.621
square feet	square meters	.093	square centimeters	square inches	.155
square yards	square meters	.836	square meters	square feet	10.764
square miles	square kilometers	2.590	square meters	square yards	1.196
acres	square hectometers	.405	square kilometers	square miles	.386
cubic feet	cubic meters	.028	square hectometers	acres	2.471
cubic yards	cubic meters	.765	cubic meters	cubic feet	35.315
fluid ounces	milliliters	29.573	cubic meters	cubic yards	1.308
pints	liters	.473	milliliters	fluid ounces	.034
quarts	liters	.946	liters	pints	2.113
gallons	liters	3.785	liters	quarts	1.057
ounces	grams	28.349	liters	gallons	.264
pounds	kilograms	.454	grams	ounces	.035
short tons	metric tons	.907	kilograms	pounds	2.205
pound-feet	newton-meters	1.356	metric tons	short tons	1.102
pound-inches	newton-meters	.11296			

## Temperature (Exact)

°F Fahrenheit temperature      5/9 (after subtracting 32)      Celsius temperature      °C

